



5-15 HP | QUIET ENCLOSED RECIPROCATING AIR COMPRESSORS

Paradox





Engineered **Excellence** Ultimate Performance

A Winning Combination

Gardner Denver compressors are proven units, known for their reliability over decades of use. We know our products and understand how they operate in many different operating environments. No matter the application, Gardner Denver gets the job done.

Revolutionary Performance

Gardner Denver has always prided itself on providing the most innovative technology to the Compressed Air marketplace. There is no better example of this than the state of the art, re-designed Quiet Enclosed Reciprocating compressor package we named the Paradox!

The revolutionary design of the Gardner Denver Paradox provides the advantages of a reciprocating compressor coupled with the low noise of a rotary screw. Ideal for areas with a low noise requirement, the Paradox can be installed directly within the work environment close to the point-of-use, which eliminates the need for a dedicated room or an outside installation. This can save hundreds of feet in piping, resulting in reduced pressure drops—ultimately increasing your bottom line, and providing another reason why Gardner Denver is the clear choice in compressed air solutions.



Design Advantages



Standard Features

- Multi-finned cylinders for cooler operating temperatures resulting in long life and consistent performance
- Two compression rings and one oil control ring to ensure low oil carry-over and provide efficient air delivery
- Large-diameter finned tubing with the greatest cooling effect between stages for maximum compressor efficiency
- Pressure relief valves located in inter-stage intercooler and discharge line for safe compressor operation
- Precision balanced flywheel with cast fan blades for optimum compressor cooling and longer life
- Removable manifolds for easy serviceability
- Balanced rugged ductile iron crankshaft with large diameter throws for minimum bearing loads and counterweights to minimize vibration
- Rugged cast iron oil reservoir with convenient sight glass gauge, corner oil fill boss and large oil drain for user-friendly serviceability
- Centrifugal unloader assures longer motor life by allowing the compressor to start unloaded every time

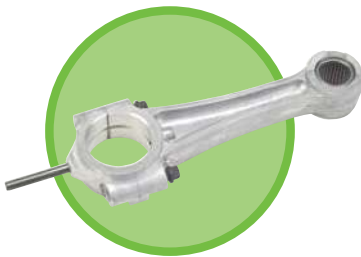

The Paradox utilizes the legendary Gardner Denver R-Series pump

Competitive Advantages & Customer Benefits

- Integral cylinder and head eliminates the possibility of blown head gaskets for **leak-free, trouble-free operation**.
- Balanced aluminum alloy first stage piston(s) are weight matched to the cast iron second-stage piston(s) for **proper balance and minimized vibration**. Unique domed piston design for **maximum air delivery and efficiency**.
- Lightweight, high-density, die-cast aluminum alloy connecting rods for **minimal reciprocating weight**. Precision-bored crankpin bearing and piston pin needle bearing are used to properly distribute bearing loads for **longer bearing life** than bushings.
- Industrial grade, reliable, high-flow, low lift disc-type valves are made of corrosion resistant steel to ensure years of **trouble-free** operation.
- Tapered roller-type main bearings, providing full contact and support of the crankshaft, ensuring compressor **durability and long-life**.

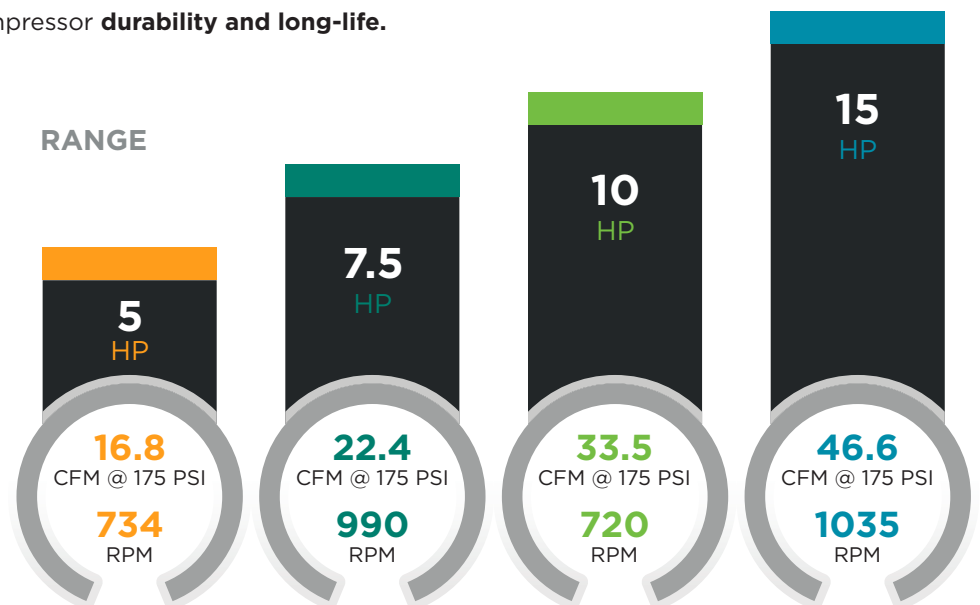

The Complete Package

Revolutionary Design

The Gardner Denver Paradox Quiet Enclosed package is a state-of-the-art design allowing for greater airflow, lower approach temperatures, and improved sound levels than seen on previous package designs. With the ability to add an optional mounted refrigerated dryer to the package, Gardner Denver continues to pave the way for innovative technology.

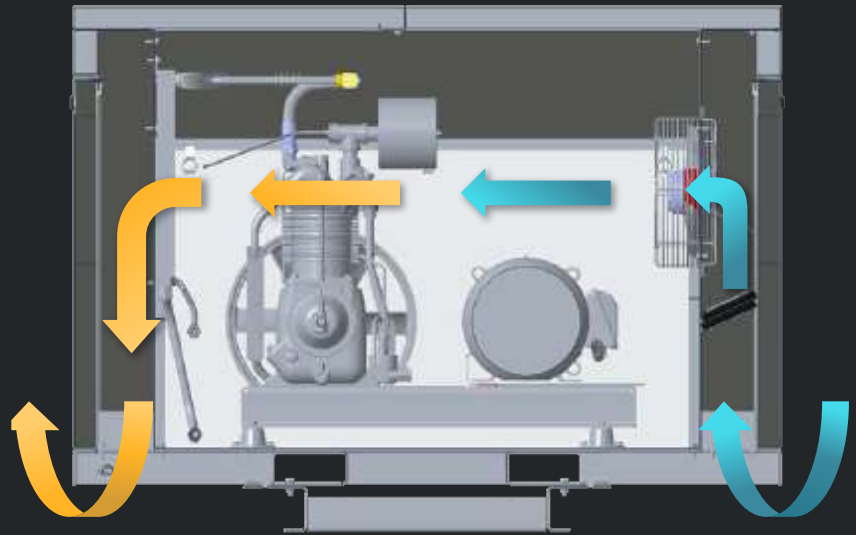

R-15

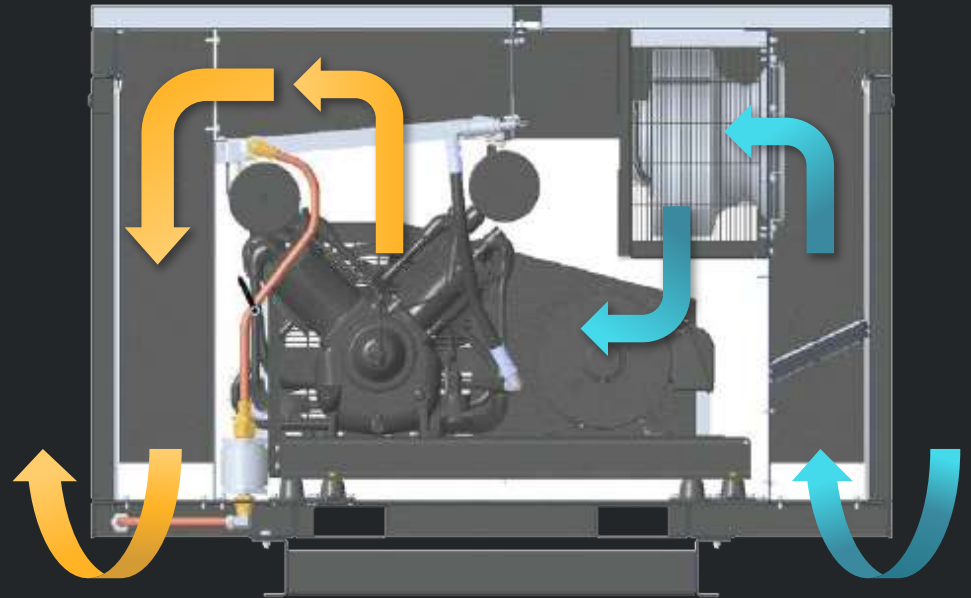

R-30



OPTIMIZED SYSTEM RELIABILITY

Our streamlined chamber design and robust cooling fan, ensures uniform cool air distribution throughout the package. This optimization provides superior air circulation, mitigating overheating the package components.



ENHANCED SERVICEABILITY

Experience easier maintenance with increased free air space inside the package, optimizing air circulation for seamless performance.



NOISE REDUCTION

Enjoy a conversation-friendly environment with our upgraded enclosed package. Our bottom intake and discharge reduces sound levels, ensuring a quieter operational environment.



IMPROVED DRYER FLEXIBILITY

Harness the benefits of our oversized aftercooler for remarkably low approach temperatures—below 20 degrees Fahrenheit—enhancing dryer performance without oversizing.

An advanced package solution engineered to exceed the demands of your business.

Paradox

5 & 7.5 HP Design Features

- 1 Filter Minder & Air Pressure Gauge
- 2 Hour Meter
- 3 Oversized Bar & Plate After-Cooler Allowing for Maximum Cooling
- 4 Pressure Switch
- 5 R-15 Pump: Legendary R-Series Compressor Pump—Best in the Industry
- 6 Isolated Sub-Base
- 7 Floor-Mounted Sub-Base
- 8 Integrated State-of-the-Art Control Panel
- 9 1,000 CFM Axial Fan
- 10 Air-Intake Pre Filter
- 11 Motor
- 12 2" Foam on External Panels
- 13 Enclosed Wire Belt Guard
- 14 Belt Tensioning System



Standard Features

- Sophisticated control panel design that includes fault and power-on light, hour meter and ON/OFF switch as standard
- Standard start/stop control
- Sound attenuating enclosure and bottom intake and discharge result in remarkably low dBA levels
- Ball valve on crankcase drain for easy maintenance of lubricant
- Front and back panels can be easily removed for fast and easy service access
- Air intake pre-filter
- 80/20 duty cycle
- Low oil stop control
- 2" foam on external panels
- Efficient bar and plate after-cooler

- Ample space throughout the package, coupled with large 1000 CFM fan
 - Makes for a less complex package
 - Provides better airflow and cooler temperatures
- Ability to run the package with the doors off for maintenance

Optional Accessories

- Mounted refrigerated air dryer
- Electronic tank drain
- Food grade oil
- High temp switch

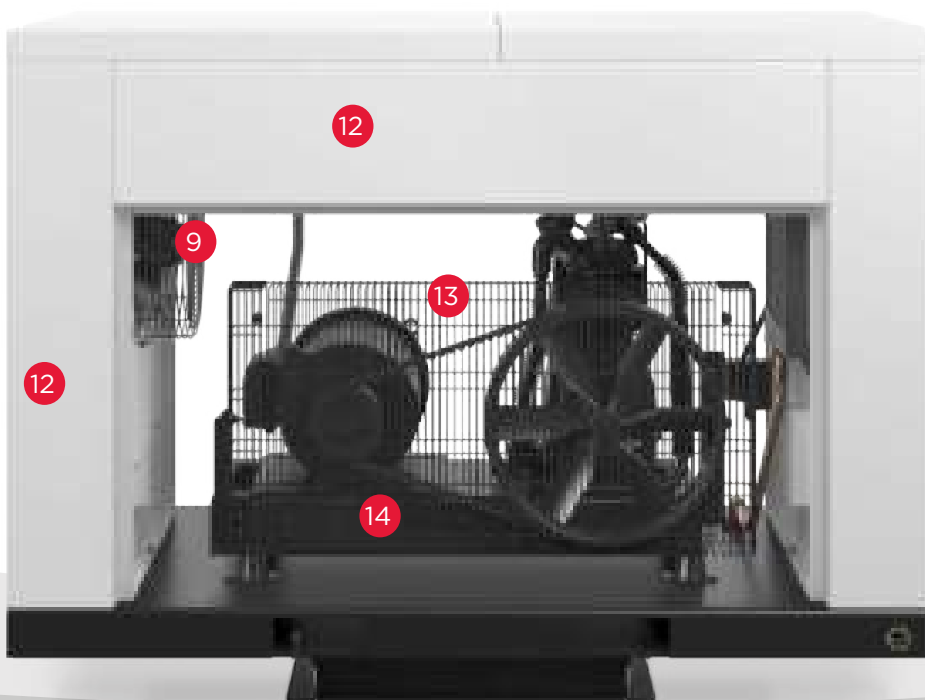

BACK

Paradox

10 & 15 HP Design Features

- 1 Filter Minder & Air Pressure Gauge
 - 2 Hour Meter
 - 3 Oversized Bar & Plate After-Cooler Allowing for Maximum Cooling
 - 4 Pressure Switch
 - 5 R-30 Pump: Legendary R-Series Compressor Pump—Best in the Industry
 - 6 Check Valve
 - 7 Isolated Sub-Base
 - 8 Floor-Mounted Sub-Base
 - 9 Integrated State-of-the-Art Control Panel
 - 10 2,000 CFM Radial Fan
 - 11 Air-Intake Pre Filter
 - 12 Motor
 - 13 2" Foam on External Panels
 - 14 Enclosed Clam Shell Belt Guard
- Belt Tensioning System (not shown)

FRONT



Standard Features

- Sophisticated control panel design that includes fault and power-on light, hour meter and ON/OFF switch as standard
- Standard start/stop control
- Sound attenuating enclosure and bottom intake and discharge result in remarkably low dBA levels
- Ball valve on crankcase drain for easy maintenance of lubricant
- Front and back panels can be easily removed for fast and easy service access
- Air intake pre-filter
- 80/20 duty cycle
- Low oil stop control
- 2" foam on external panels
- Efficient bar and plate after-cooler

- Ample space throughout the package, coupled with large 2000 CFM fan
 - Makes for a less complex package
 - Provides better airflow and cooler temperatures
- Ability to run the package with the doors off for maintenance

Optional Accessories

- Mounted refrigerated air dryer
- Electronic tank drain
- Food grade oil
- High temp switch

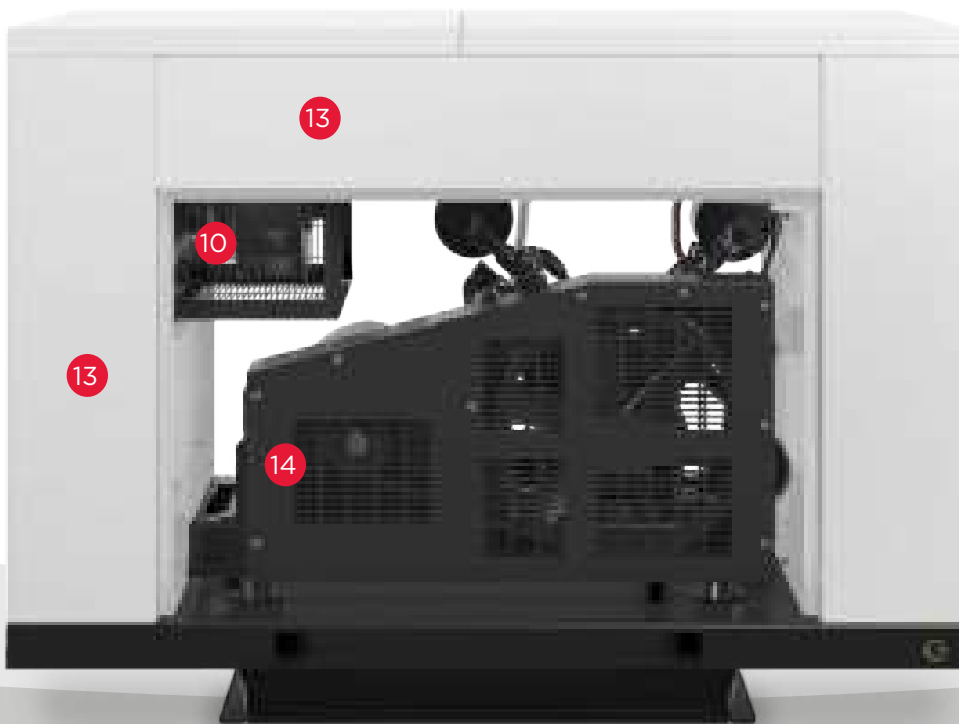

BACK

Sound Testing

Performance and sound testing data gathered through extensive product development and research conducted in our laboratories to ensure that the Paradox meets or exceeds all of our requirements. The continued commitment by Gardner Denver to our customers' needs is essential in providing the most reliable and innovative technologies in the marketplace.

Paradox tested to CAGI adopted ISO 2151 certified standards



Nearly **SILENT** Noise Levels

The Gardner Denver Paradox compressor features high-quality, 2-inch foam sound-insulating enclosure panels and a low-noise, thermostatically-controlled, motor-driven fan. These components reduce the noise to whisper-quiet levels and eliminate the need for a separate compressor room, saving money on installation costs.



Pump Model R-15B

PARADOX 5-7.5 HP SIMPLEX UNITS

MOTOR	TANK CAPACITY	PACKAGE MODEL NUMBER	DIMENSIONS L x W x H		APPROX. SHIP WEIGHT		AVERAGE UNENCLOSED RECIP PACKAGE SOUND LEVEL	PARADOX SOUND LEVEL	175 PSI RATING	
			LESS DRYER	WITH DRYER	LESS DRYER	WITH DRYER			RPM	CFM DEL'Y
HP	GAL		INCHES	INCHES	LBS	LBS	DBA	DBA		
5	-	BQR5	61 x 32 x 45	-	1114	-	75	63	734	16.8
5	80	HQR5-8	70 x 32 x 64	71 x 32 x 64	1285	1401			734	16.8
7.5	-	BQR7F	61 x 32 x 45	-	1141	-	77	65	990	22.4
7.5	80	HQR7F	70 x 32 x 64	71 x 32 x 64	1312	1412			990	22.4

Pump Model R-30D

PARADOX 10-15 HP SIMPLEX UNITS

MOTOR	TANK CAPACITY	PACKAGE MODEL NUMBER	DIMENSIONS L x W x H		APPROX. SHIP WEIGHT		AVERAGE UNENCLOSED RECIP PACKAGE SOUND LEVEL	PARADOX SOUND LEVEL	175 PSI RATING	
			LESS DRYER	WITH DRYER	LESS DRYER	WITH DRYER			RPM	CFM DEL'Y
HP	GAL		INCHES	INCHES	LBS	LBS	DBA	DBA		
10	-	BQR10	68 x 33 x 50	-	1371	-	78	62	720	33.5
10	120	HQR10-12	76 x 33 x 74	93 x 33 x 71	1647	1764		65	720	33.5
15	-	BQR15F	68 x 33 x 50	-	1440	-	82	65	1035	46.6
15	120	HQR15F-12	76 x 33 x 74	93 x 33 x 71	1716	1833		68	1035	46.6

Bare Pumps

R-SERIES RECIPROCATING COMPRESSOR

MODEL	# OF CYL-INDERS	BORE DIA.	STROKE	OIL CAPACITY	PUMP DIMENSIONS L x W x H	APPROX SHIP WEIGHT	MIN PUMP RPM	MAX PUMP RPM
		INCHES	INCHES	QTS	INCHES	LBS		
R-15	2	4.63 x 2.5	3	2	20 x 17 x 24	135	400	1050
R-30	4	4.63 x 2.5	3	4	22 x 24 x 24	240	400	1050

Convenience & Peace of Mind

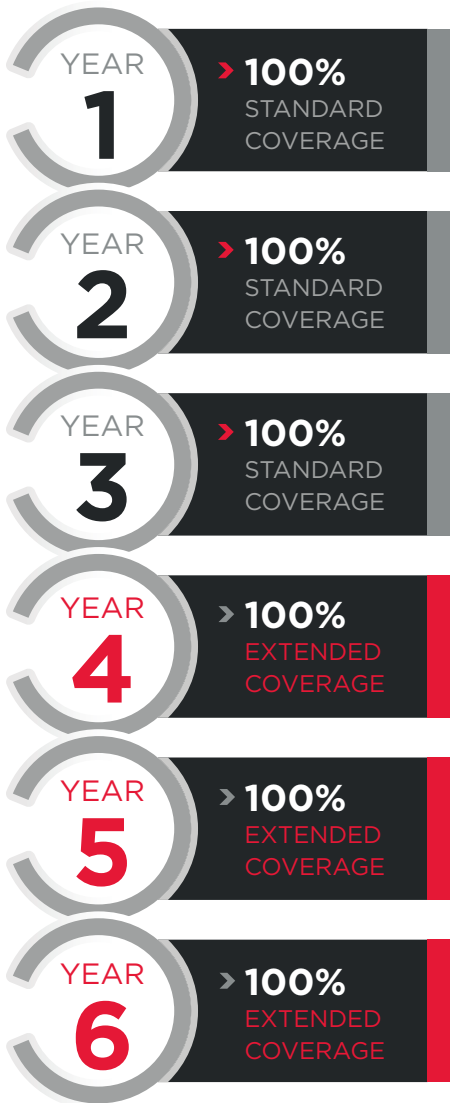

Standard Warranty

The standard warranty covers parts and labor on the package components for one year and three years on the compressor pump.



The Gardner Denver philosophy ensures long-lasting, reliable equipment. Our warranty program demonstrates our confidence in our products. Each new Gardner Denver assembled unit has a 3 year warranty on the compressor pump against defects in materials of workmanship under normal use and service.

*See standard warranty form BU-49 for complete standard warranty details.

Premium Extended Warranty

Purchase a Premium Warranty Kit at the same time as your new Gardner Denver compressor package to receive extended warranty protection. This offer will double the coverage with an additional 3 years of warranty on the compressor pump (parts & labor) providing 6 YEARS of worry free coverage. The Premium Extended Warranty also provides an extra 12 months coverage on the package for a total of 24 months. See Premium Warranty form BU-51 for complete extended warranty details.

- Premium Warranty kit has all necessary service items (oil & filters) for 6 years of annual maintenance.
- The use of approved Gardner Denver lubricants are required to maintain the extended warranty period.



Sales & Service **Distributors** Across America

An Extensive Network

By leveraging the extensive network of Gardner Denver factory-trained authorized local distributors, your sales, service and technical support needs can be handled quickly and easily.



To find a distributor visit:
GardnerDenver.com

The leader in every market we serve
by continuously improving all business processes
with a focus on innovation and velocity

Gardner

Denver[®]

1800 Gardner Expressway
Quincy, IL 62305
www.gardnerdenver.com



©2024 Industrial Technologies and Services, LLC
Printed in U.S.A.
GR-PARADOX 3rd Ed. 6/24

